

Operating manual  
**ZF hysteresis clutches and brakes**

Subject to alterations in design

Copyright by ZF

This operating manual is protected by copyright.

Printed in Germany

Edition: 11.2005

Companies who repair ZF units are always responsible for their own work safety.

**To avoid injury to staff and damage to products during maintenance and repair work, compliance must be maintained with all relevant safety regulations and legal requirements.**

**Before starting work, mechanics must familiarize themselves with these regulations.**

**Staff required to carry out repairs on ZF products must receive appropriate training in advance. It is the responsibility of each company to ensure that their repair staff are properly trained.**

The following safety instructions are used in this operating manual:

### **NOTE**

**Note** refers to special processes, techniques, information, etc.

### **CAUTION**

**This is used when incorrect and unprofessional working practices could damage the product.**



### **DANGER !**

**This is used when lack of care could lead to personal injury or death.**

---

## General information

---

Read this manual carefully before starting any installation work.

**After installation and electrical connection skilled staff must satisfy themselves that the product is functioning correctly.**

<b>1</b>	<b>Introduction</b> .....	<b>6</b>
<b>2</b>	<b>Typical applications</b> .....	<b>7</b>
<b>3</b>	<b>Special features</b> .....	<b>8</b>
<b>4</b>	<b>Structure / function</b> .....	<b>10</b>
<b>5</b>	<b>Installation / assembly of clutch</b> .....	<b>12</b>
<b>6</b>	<b>Installation / assembly of brake</b> .....	<b>13</b>
<b>7</b>	<b>Mechanical loads</b> .....	<b>14</b>
<b>8</b>	<b>Electric commissioning</b> .....	<b>15</b>
<b>9</b>	<b>Electronic control unit</b> .....	<b>16</b>
<b>10</b>	<b>Residual magnetism</b> .....	<b>17</b>
<b>11</b>	<b>Maintenance</b> .....	<b>18</b>
<b>12</b>	<b>Fault detection and causes</b> .....	<b>19</b>
<b>13</b>	<b>ZF contacts</b> .....	<b>21</b>

## 1 Introduction

In a large number of applications, accurately adjustable torque levels and tension are an essential precondition for the precise processing of high-quality products.

In this context, accurate reproducibility as well as consistency of the torque level set are also a precondition, especially for procedures not subject to feedback control.

These requirements are best satisfied through the use of electro-magnetic, zero-contact hysteresis clutches/brakes in conjunction with feedback control electronics designed for this purpose.

## 2 Typical applications

One characteristic application is the creation of a precisely defined tension when unreeling endless products such as wire, thread, paper, foils from feed rollers.

The change in diameter between the full and empty roller must be recorded, processed by electronic control unit and converted by a brake in the form of an adapted torque level to ensure constant tension.

Reeling up procedures are realised in the same way using hysteresis clutches.

The recording of characteristics curves of electric motors and many other load simulations can also be conducted using hysteresis brakes by creating an accurately adjustable braking torque.

### Diagram of track unreeling

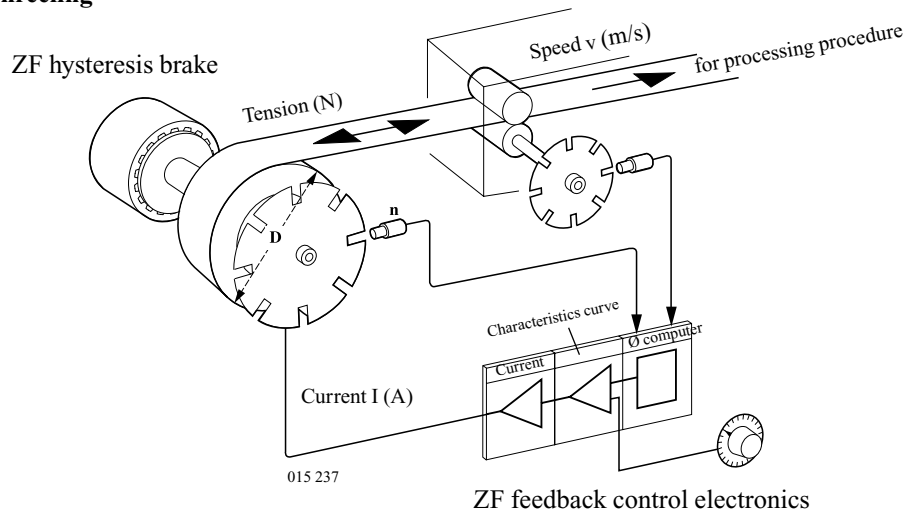

### 3 Special features of hysteresis technology

- Zero-contact transfer of torque
- No friction noise
- No friction coefficient fluctuations
- No stick-slip effect
- No wear
- Standstill torque / synchro torque present

The torque created depends on the current level set in the energized coil and can be continuously adjusted up to a type-related maximum value.

There is no influence from speed, with the exception of a slight, almost linear increase in torque which occurs with an increasing slip speed.

This increase in torque is more distinct over the entire speed range in the performance oriented model range.

Another key feature of hysteresis technology is the ability to transfer torque without a transition both synchronously as well as when slipping.

The torque is therefore also effective when at a standstill.



## Torque-current characteristics curve

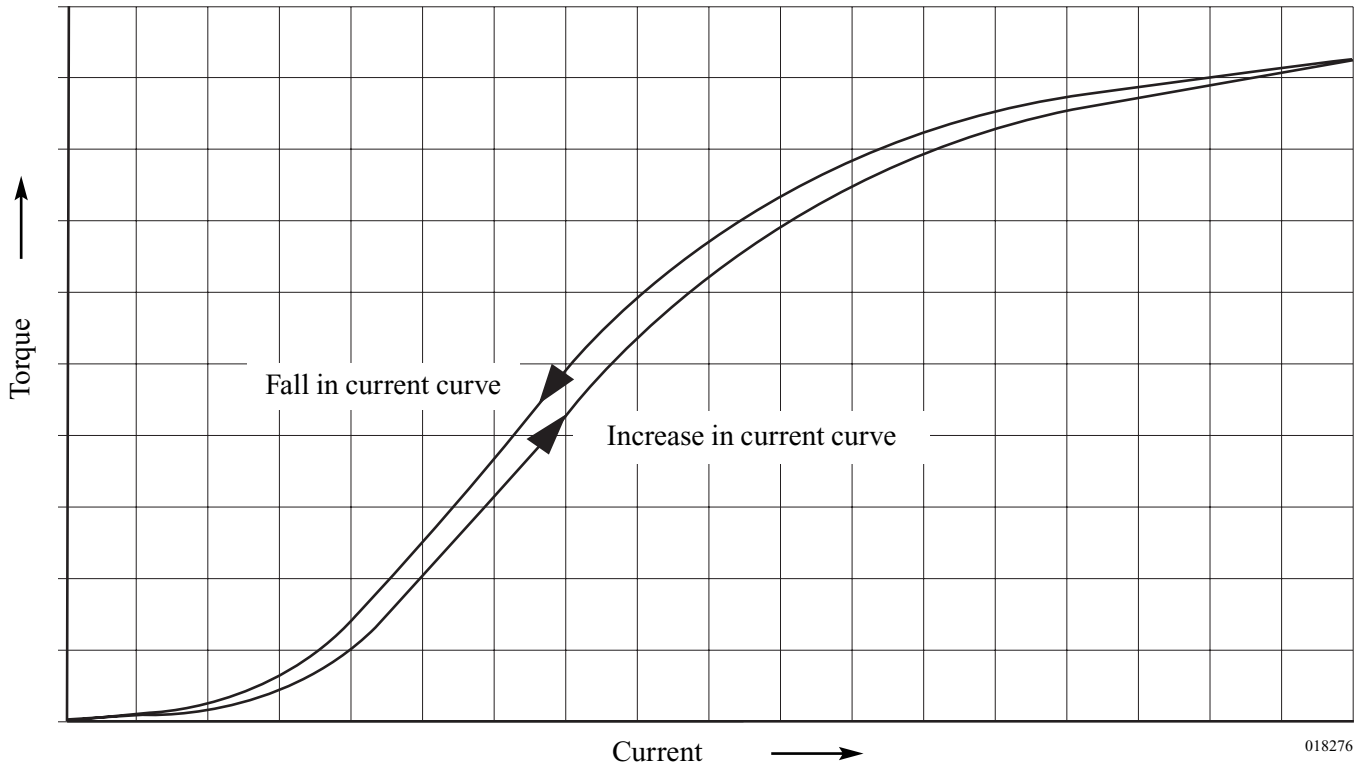

## 4 Structure / function

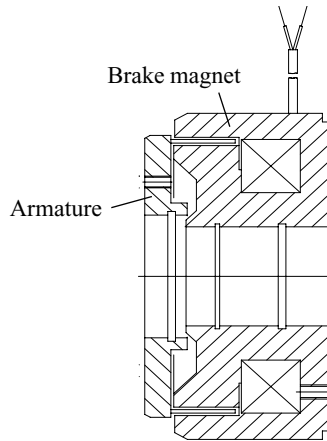

**Brake**

The static magnet contains the energized coil, which induces the magnetic flux in the rotor. Outer and inner pins are offset against one another in the rotor and what is commonly referred to as the hysteresis ring (made of permanently magnetic material) can move freely between these pins (brake: magnet body and rotor form one component).

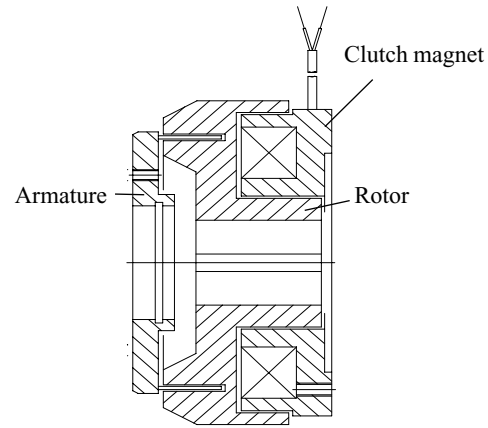

**Clutch**

Depending on the number of pins, the coil energy in the hysteresis ring results in multiple tangential magnetisation with an alternating pin orientation. The attracting and/or repelling forces of the permanent magnetic zones created in this way result in the transferable synchronous torque.

Pin geometry

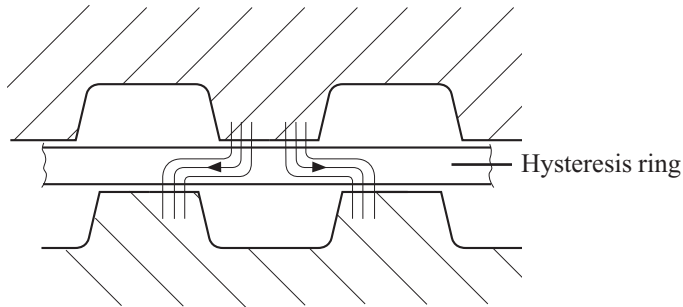

019436

Hysteresis loops depending on controller input

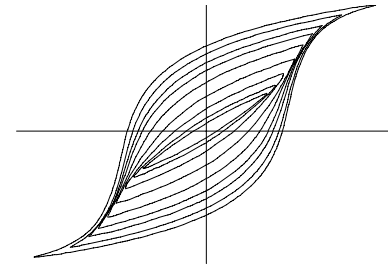

When there are differences in speed between the rotor and hysteresis ring (continuous slip operation), the elementary magnets are continuously rectified.

This occurs contrary to a material-dependent resistance whereby each elementary magnet passes through the known hysteresis loop in a one terminal position.

The name “hysteresis clutch/brake” is derived from this.

### 5 Installation / assembly of clutch

The static clutch magnet is centred using the centring diameter on the connection piece and secured using screws.

The rotor is usually connected to the driven shaft by means of a key (so that it cannot twist) and secured axially e.g. using circlips or spacer bushes.

As a result of the lower level of inertia torque, the armature usually forms the output end and is screwed onto the connection piece.

The inertia torques only play a subordinate role and if the design situation produces a more favourable arrangement, the armature may form the input end and the rotor the output end.

All components must be secured axially.

#### **NOTE**

If detailed installation investigations are required, the relevant installation drawing can be requested from the contacts given in the Annex.

It is essential that the components are assembled in a concentric manner.

#### **CAUTION**

**The eccentricity of the magnet bodies, rotor and armature components must not be greater than 0.1 mm - otherwise there is a risk of radial contact.**

It is advisable for the radial arrangement of the components to be established using bearings.

### 6 Installation / assembly of brake

The brake magnet is centred using the centring diameter on the connection piece and secured using screws.

The armature is screwed onto the connection piece and must be secured axially.

#### NOTE

If detailed installation investigations are required, the relevant installation drawing can be requested from the contacts given in the Annex.

It is essential that the components are assembled in a concentric manner.

#### CAUTION

**The eccentricity of the armature must not be greater than 0.1 mm - otherwise there is a risk of radial contact.**

The radial arrangement of the components can be established using bearings.

### 7 Mechanical loads

Component loads, caused e.g. as a result of the effects of radial or axial loads, should be checked in each individual instance.

If working with mounted hysteresis brake units, the bearing types and bearing arrangement can be used to undertake a service life calculation for a specified load level.

#### **NOTE**

For service life investigations, the relevant installation drawing or the “ZF-TIRATRON” catalogue can be requested from the contacts given in the Annex.

In particular, weight loads, resulting from feed rollers, should always be appropriate for the brake size.  
If these are too great, we would recommend a separate mounting, connecting to the brake by means of a flexible shaft coupling.

### 8 Electric commissioning

The hysteresis clutches/brakes are activated by constant direct current. Ideally, the “ZF ERM electronic control unit” (feedback control electronics) are used in conjunction with a direct current supply for this purpose.

#### **NOTE**

The “ZF ERM electronic control unit” operating manual can be requested from the contacts given in the Annex.

Before commissioning, operators must ensure that the operating voltage of the current supply is within the permissible range and that its rating is sufficient.

If the clutch or brake ready for operations is subjected to current, the adjustable torque level of between zero (bearing friction) and the nominal value can be set in accordance with the torque-current characteristics curve of the type used.

#### **CAUTION**

**The nominal current of the type used must not be exceeded.**

### NOTE

Electrical equipment must be installed by trained specialists.

Comply with all applicable relevant safety regulations.

On principle, there is no need to pay attention to the polarity of the pigtails of clutch and brake.

If units are mounted to each other (e.g. back-to-back), there might be a reciprocal magnetic interference, which can also depend on the polarity.

Type	Nominal current [A]
EBU 0.05	0.225
EBU 0.1	0.4
EBU 0.3	0.75
EBU 1	1.25
EBU 3	1.25
EBU 10	1.5
EBU 30	2.2
EBU 250/1	1.1
EBU 500/3	1.4
EBU 1000/10	1.9
EBU 2000/30	2.7
EBU 500/30 G	1.4
EBU 1000/100 G	1.9
EBU 2000/300 G	2.7
EBU 2000/600 G	2.7
EKU 0.3	0.9
EKU 1	1.3
EKU 3	1.5
EKU 10	1.8

### 9 Electronic control unit

In order to be able to maintain the tension and/or torque consistency required despite changes in the diameter of a material on a reel or other process influences, perfectly fine-tuned activation electronics are required to control and/or feedback control the hysteresis clutches/brakes depending on application.

When using “ZF ERM electronic control unit”, a number of different operating modes are available.

These electronics assure the correct current supply to clutch / brake depending on a nominal value specification. They are controlled by a microprocessor and equipped with programmer, operating and diagnosis interfaces.

#### **NOTE**

The “ZF ERM electronic control unit” operating manual can be requested from the contacts given in the Annex.



## 10 Residual magnetism

This effect may occur when the activation current is taken away and can be observed, e.g. in sudden irregular movements, which may be undesirable or harmful depending on the system process (product cannot be set up by hand, product cracks).

This wave-type residual torque, commonly referred to as the “Ripple effect” is caused by residual magnetism which occurs if the current jumps or changes to less than 50% of the original value without the armature turning in relation to the brake magnet and/or clutch rotor.

During this process, permanently magnetic zones are imprinted into the hysteresis ring, depending on the number of pin pairs. When the unit is not (or is only slightly) energized, these can be seen in the form of a wave-shaped residual torque.

### NOTE

The effect can be dependably prevented if the current is controlled downwards in a ramp form with a simultaneous relative movement of the armature.

If residual magnetism is still applied, e.g. accidentally, this can be cancelled at any time.

### NOTE

If a hysteresis clutch/brake is subjected to a process with residual magnetism, this can be deleted by subjecting the unit to nominal current and then reducing the current to zero, whereby at the same time the armature rotates at least once relative to the brake magnet or clutch rotor.

If the (higher) initial current is again reached in a subsequent operating cycle during the process, any possible residual magnetism is also rectified.

### 11 Maintenance

As a result of the zero-contact function, the components of the hysteresis clutches and brakes are not subject to any wear.

Under the permissible operating conditions, i.e. when observing the limit values defined in the catalogue and complying with the usual laws of technology, only the service life of the bearings is restricted (grease service life).

The ball bearings of the hysteresis brakes available as mounted units are filled with grease and, according to the manufacturer, require zero maintenance.

The service life of the bearings depends on load (also refer to “7. Mechanical loads”), dirt and temperatures etc.

## 12 Fault detection

Fault	Possible cause	Remedy
Clutch / brake not creating torque despite power supply being connected	Mains component defective	Check / replace mains component
	Connections defective	Check / replace connection cable
	Clutch/brake magnet (coil) defective	Replace clutch/brake magnet (ZF service address)
	Mechanical components connection, e.g. armature/shaft and/or rotor/shaft missing	Fit key for armature/shaft and/or rotor/shaft connection or alternative connection technique (press, glue)
Clutch / brake supplying the “incorrect” torque (size of torque)	Activation incorrect	Check nominal value specification
		Check ERM set parameters for operating mode required acc. to “ZF ERM electronic control unit” operating manual
	Radial contact of armature/rotor	Check installation; eccentricity max. 0.1 mm, see “Installation / assembly” chapter
	Axial contact of armature/rotor	Check installation; axial arrangements of components acc. to installation drawing / “ZF-TIRATRON” catalogue

Fault	Possible cause	Remedy
Noise	Particles in air gap	Clean / blow out with compressed air
	Radial contact of armature/rotor	Check install.; excentricity max. 0.1 mm, see “Installation / assembly” chap.
	Axial contact of armature/rotor	Check installation: axial arrangements of components acc. to installation drawing / “ZF-TIRATRON” catalogue
Not energized, wave-shaped residual torque, brake or clutch ripple	Residual magnetism	Refer to “Residual magnetism” chapter
	Radial contact of armature/rotor	Check installation: excentricity max. 0.1 mm, see “Installation / assembly” chapter

### NOTE

If the armature/rotor is reworked as a remedial measure to alleviate radial contact, the properties (characteristics curve) will be changed.

### 13 ZF contacts

Requests for catalogue documents or installation drawings:

- “ZF-TIRATRON” catalogue
- “ZF ERM electronic control unit” operating manual

ZF Friedrichshafen AG  
Sonder-Antriebstechnik  
Special Driveline Technology  
88036 Friedrichshafen / Germany  
Tel. +49(0)7541-77-3300  
Fax +49(0)7541-77-2379  
E-mail: [industrial-drives@zf.com](mailto:industrial-drives@zf.com)

Service contact

Please refer to the overview on our website at  
[www.zf.com/industrial-drives](http://www.zf.com/industrial-drives)  
for the address of your nearest service centre.