

SCREW JACK DATA SHEET

BJ3 TRANSLATING SCREW

Specifications:

Ratio:	Normal 10:1	Low 40:1
Max lifting force:	250kN	250kN
Spindle:	TR80x10	TR80x10
Max power:	9.0kW	9.0kW
Stroke per input rev:	1mm	0.25mm
Travel speed with 4 pole motor (approx)	25mm/sec	6mm/sec
Total efficiency:	21.7%	15.8%
Idling torque:	1.42Nm	1.09Nm
Drive torque at max lifting force:	205Nm	93Nm
Max permissible torque at worm shaft:	290Nm	290Nm
Gear housing material:	Cast iron	Cast iron
Weight (less spindle & tube):	57kg	57kg
Weight of spindle per 100mm:	4.2kg	4.2kg
Amount of grease filling:	1.9kg	1.9kg
Lubrication:	Divinol Lithogrease 1500	Divinol Lithogrease 1500

Order code:

BJ3-	2	3	4	5	6	7	8
------	---	---	---	---	---	---	---

2:	Version:	GN = Normal ratio version GL = Low ratio version
3:	Installation position:	1F, 2F, 3F, 4F, 5F, 6F, 1E, 2E, 3E, 4E, 5E, 6E
4:	Spindle:	TR80x10 = trapezoidal KGT = ball screw – on request +VS = keyed rotation prevention
5:	Stroke:	0000mm
6:	Spindle end:	Z = journal; FP = mounting flange; GE = threaded; GK = male clevis; KGK = rod end bearing; GS = Female clevis
7:	Accessories:	A or B = mounting side of motor; AS = spindle travel limiter; BL = mounting feet; ES = limit switch; FB = folding bellows; KP = trunnion adaptor; MG = motor adaptor; RP = flexible coupling; SF = spiral sleeve; VS = rotation prevention via square tube; SFM = safety nut
8:	Special requirements:	As specified

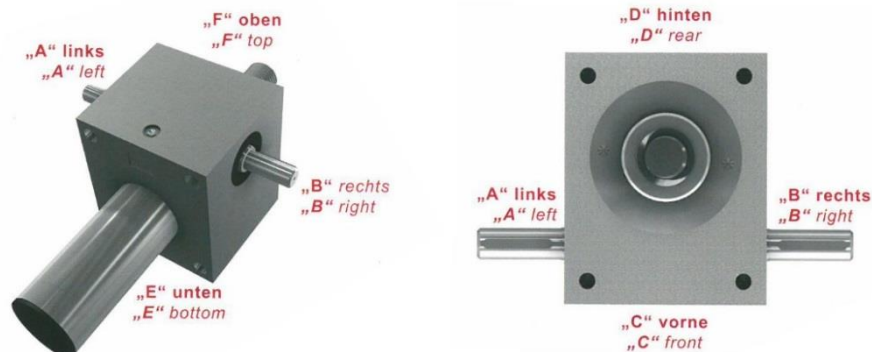

Dimensions:

A:	355mm
A1:	225mm
B:	240mm
C:	220mm
D:	170mm
E:	190mm
F:	67.5mm
G:	80mm
H:	56mm
I:	25mm
J dia:	30mmj6
K:	M30
L:	60mm
M dia:	80mmH7
N1:	82mm
N2:	83mm
O:	60mm
Q dia:	125mm
S:	165mm
S1:	216mm
T:	110mm
U:	40mm
V:	120mm
Y:	8mm
Z:	45mm
With spindle travel limiter:	
L3:	113mm
With square tube:	
L2:	118mm
Q1 sq:	120mm
Q2:	170mm
Q3:	10mm
Motor adaptor mounting holes:	As required

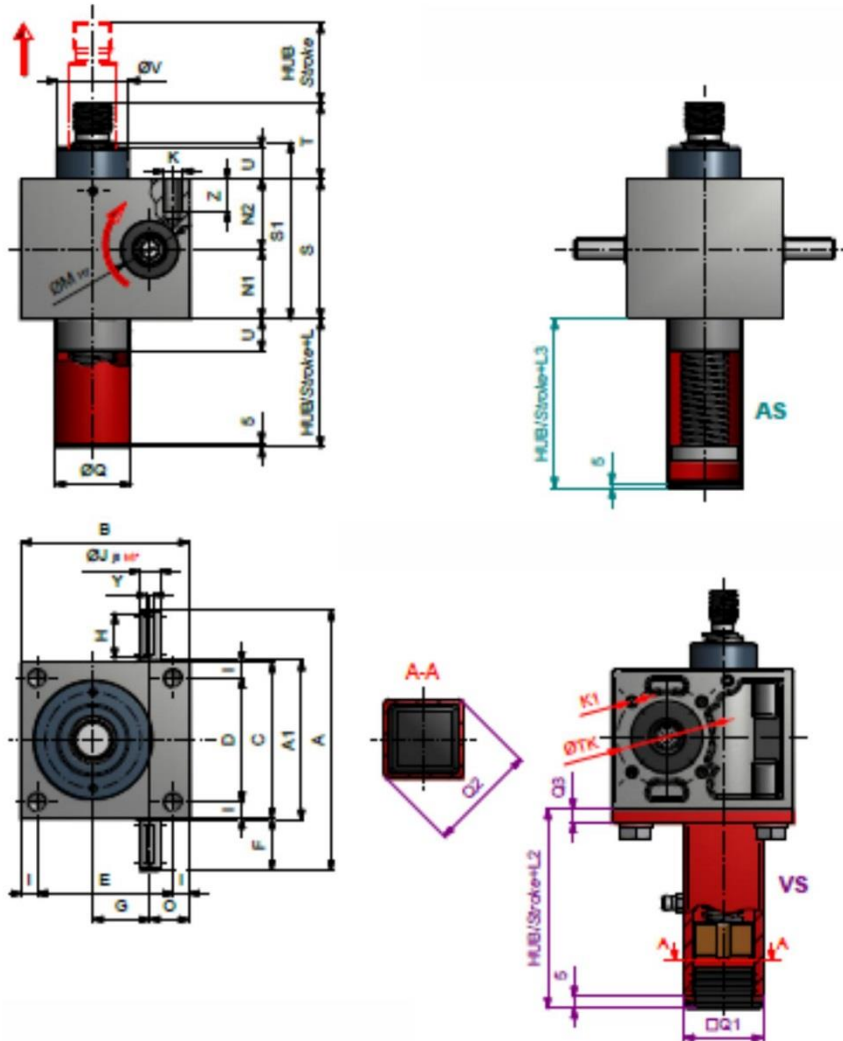

Materials:

Component	Standard	Optional
Gear housing:	Cast iron GGG-50	Stainless steel V4A; zinc plated; painted
Worm shaft:	42CrMo4	Stainless steel V4A, V2A
Spindle:	C45 Steel 1.0503	Stainless steel V4A, V2A
Spindle protection tube:	C37 Steel 1.0122	Stainless steel V4A; zinc plated; painted
Bearing cover:	C45 Steel 1.0503	Stainless steel V4A; zinc plated; painted

V4A = 1.4571 V2A = 1.4305