

POWERGEAR DATA SHEET P-450



L Series



FL Series



H Series



FH Series

Specifications:

Ratio:	1:1	1.5:1	2:1	3:1	4:1	5:1
Nominal output torque:	6600Nm	7000Nm	7000Nm	7000Nm	6600Nm	6000Nm
Acceleration torque:	9900Nm	10500Nm	10500Nm	10500Nm	9900Nm	9000Nm
Emergency torque:	13200Nm	14000Nm	14000Nm	14000Nm	13200Nm	12000Nm
Input speed:	550rpm	800rpm	800rpm	1100rpm	1100rpm	1100rpm
Max input speed (Special measures on request)	1300rpm	1300rpm	1300rpm	1300rpm	1300rpm	1300rpm
Standard output backlash:	≤ 10 arcmin	≤ 10 arcmin	≤ 10 arcmin	≤ 10 arcmin	≤ 10 arcmin	≤ 10 arcmin
Reduced output backlash:	≤ 5 arcmin	≤ 5 arcmin	≤ 5 arcmin	≤ 5 arcmin	≤ 5 arcmin	≤ 5 arcmin
Permissible radial load*: (Output)	34000N	34000N	34000N	34000N	34000N	34000N
Permissible radial load*: (Input)	22000N	22000N	22000N	18000N	15000N	11000N
Permissible axial load*: (Output)	17000N	17000N	17000N	17000N	17000N	17000N
Permissible axial load*: (Input)	11000N	11000N	11000N	9000N	7500N	5500N
Efficiency at max load:	>98%	>98%	>98%	>98%	>98%	>98%
Running noise at 1500rpm, partial load	≤ 85db(A)	≤ 85db(A)	≤ 85db(A)	≤ 85db(A)	≤ 85db(A)	≤ 85db(A)
Weight:	400.0kg	400.0kg	400.0kg	400.0kg	400.0kg	400.0kg
Service life:	>15,000h	>15,000h	>15,000h	>15,000h	>15,000h	>15,000h
Oil quantity:	22.0 litres	22.0 litres	22.0 litres	22.0 litres	22.0 litres	22.0 litres
Operating temperature:	Up to 80°C	Up to 80°C	Up to 80°C	Up to 80°C	Up to 80°C	Up to 80°C
Mass moments of inertia related to input for shaft arrangement 13:	7632kg/cm ²	4152kg/cm ²	2764kg/cm ²	1596kg/cm ²	1077kg/cm ²	750kg/cm ²

*At centre of shaft

Order code:

P-	450-	2-	3-	4-	5-	6-	7
----	------	----	----	----	----	----	---

2:	Version:	L = solid shaft version; FL = solid shaft version with input flange H = hollow shaft version; FH = hollow shaft version with input flange
3:	Ratio:	1:1; 1.5:1; 2:1; 3:1; 4:1; 5:1
4:	Shaft arrangement:	Wa1; Wa3; Wa12; Wa13; Wa23; Wa123
5:	Mounting position:	MP1; MP2; MP3; MP4; MP5; MP6
6:	Input speed:	????rpm
7:	Special requirements:	As specified

Dimensions

a:	360mm
b dia:	350mmH7
c dia:1:1 to 2:1	210mm
c dia: c dia:3:1 to 5:1	170mm
d1 dia: 1:1 to 2:1	75mmk6
d1 dia: 3:1	60 mmk6
d1 dia: 4:1	55 mmk6
d1 dia: 5:1	50 mmk6
l1: dia: 1:1 to 2:1	120mm
l1: dia: 3:1	110mm
l1: dia: 4:1	85mm
l1: dia: 5:1	80mm
d2 dia:	75mmk6
d3 dia:	75mmH7
l2:	120mm
l3:	165mm
l4:	105mm
e:	180mm
f1: 1:1 to 2:1	445mm
f1: 3:1	435mm
f1: 4:1	410mm
f1: 5:1	405mm
f2:	325mm
g1:	22mm
g2:	22mm
h:	145mm
k:	M20x37.5mm
m1:	325mm
m2:	205mm
n1:	3mm
n2:	3mm
p:	140mm
r1:	M20 (except 5:1 which is M16)
r2:	M20
s:	-
t:	-
u dia:	-
v dia:	-
Key d1: 1:1 to 2:1	20x12x110mm
Key d1: 3:1	18x11x100mm
Key d1: 4:1	16x10x80mm
Key d1: 5:1	14x9x70mm
Key d2:	20x12x110mm
Z:	-
Input shaft d1 dia x L1 with keyway to DIN6885/1	-

L Series

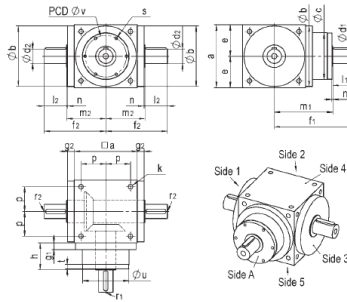

H Series

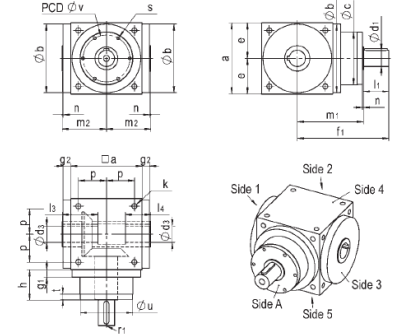

Thermal performance limit (P) = 93.4kW at 20°C and 100% duty cycle

Duty cycle:	100%	80%	60%	40%	20%
Factor:	1.0	1.2	1.4	1.6	1.8
Ambient temp:	10°C	20°C	30°C	40°C	50°C
Factor:	1.2	1.0	0.87	0.75	0.62

Eg: Duty cycle = 80%; ambient temp = 30°C Therefore P = 93.4 x 1.2 x 0.87 = 97.50kW

Shaft arrangements L:

Always right view – mirrored illustration

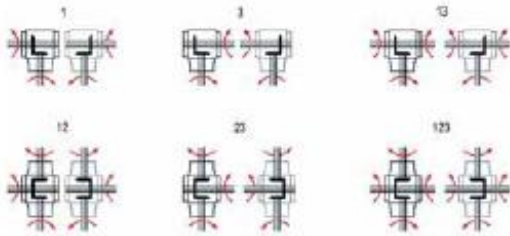

Shaft arrangements H:

Always right view – mirrored illustration

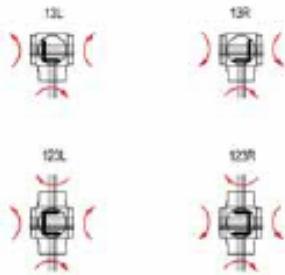

Mounting positions:

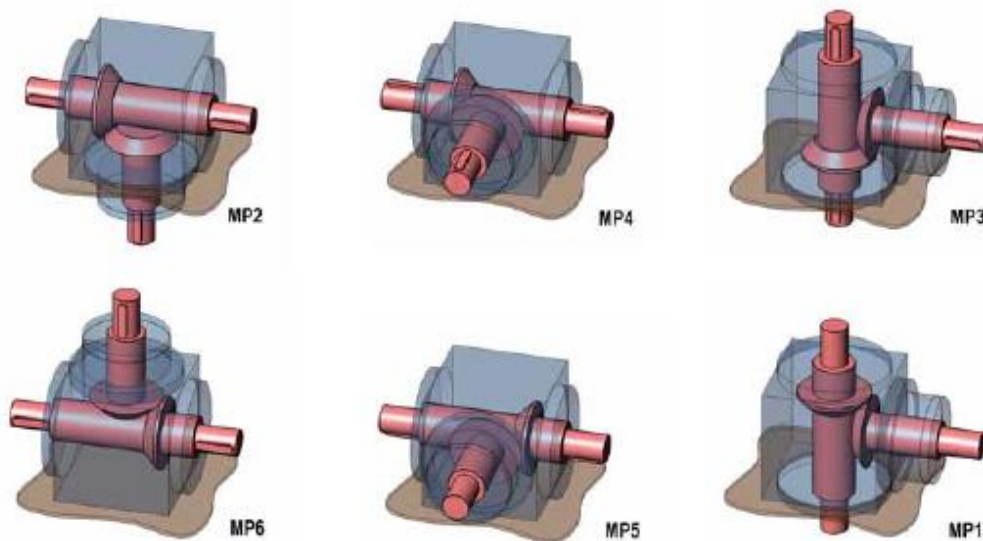

For full specifications, see PowerGear catalogue.

Please note: P-450 supplied without lubricant. Please order separately.